

## Kit Standard Taper AQB + Standard Gasket

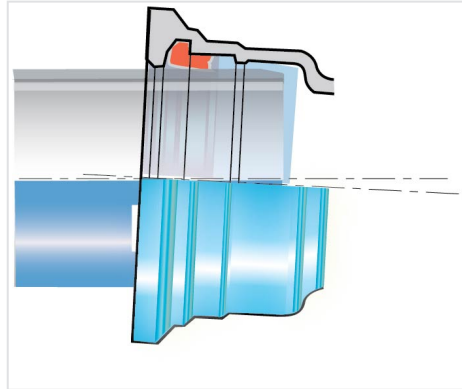

DN	Ø dn	Weight of Kit	References
100	80	7.85 kg	NSB10VE0ENN2-E00
150	100	11.59 kg	NSB15VE0FNN2-E00
200	100	17.88 kg	NSB20VE0FNN2-E00
200	150	17.37 kg	NSB20VE0JNN2-E00
250	125	24.14 kg	NSB25VE0GNN2-E00
250	200	23.08 kg	NSB25VE0KNN2-E00
300	200	33.09 kg	NSB30VE0KNN2-E00
300	250	31.71 kg	NSB30VE0LNN2-E00

DN mm	Class	PFA bar
80	C40	40
100	C40	40
125	C40	40
150	C40	40
200	C40	40
250	C40	40
300	C40	40

## Linked products



## Standard gasket for Pipes and Fittings DN60-2000

*The information on this sketch is, to the best of our knowledge correct at the time of printing. However Saint-Gobain are constantly looking at ways of improving their products and services therefore reserve the right to change without prior notice, any of the data shown. Any orders placed will be subject to our Standard Conditions of Sale, available on request.*