

## Kit Standard All Socket Tee AQB + Standard Gasket

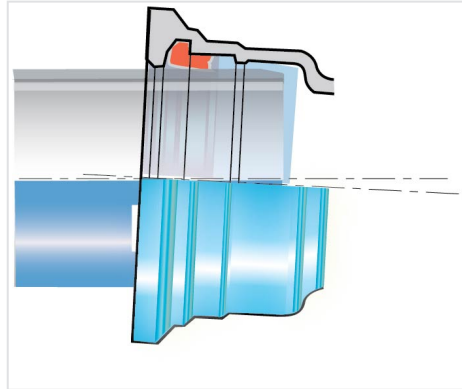

DN	Ø dn	Weight of Kit	References
60	60	9.03 kg	NSA60TE0CNN2-E00
80	80	11.65 kg	NSA80TE0ENN2-E00
100	100	15.5 kg	NSB10TE0FNN2-E00
125	80	16.13 kg	NSB12TE0ENN2-E00
125	100	33.08 kg	NSB12TE0FNN2-E00
125	125	21.72 kg	NSB12TE0GNN2-E00
150	80	18.93 kg	NSB15TE0ENN2-E00
150	100	20.58 kg	NSB15TE0FNN2-E00
150	150	27.87 kg	NSB15TE0JNN2-E00
200	100	28.46 kg	NSB20TE0FNN2-E00
200	125	30.7 kg	NSB20TE0GNN2-E00
200	150	33.35 kg	NSB20TE0JNN2-E00
200	200	41.84 kg	NSB20TE0KNN2-E00
250	80	31.75 kg	NSB25TE0ENN2-E00
250	100	33.5 kg	NSB25TE0FNN2-E00
250	150	38.19 kg	NSB25TE0JNN2-E00
250	200	43.38 kg	NSB25TE0KNN2-E00
250	250	51.2 kg	NSB25TE0LNN2-E00
300	100	42.62 kg	NSB30TE0FNN2-E00
300	150	47.71 kg	NSB30TE0JNN2-E00
300	200	53.9 kg	NSB30TE0KNN2-E00
300	250	62.32 kg	NSB30TE0LNN2-E00

DN	Ø dn	Weight of Kit	References
300	300	71.13 kg	NSB30TE0MNN2-E00

DN mm	Class	PFA bar
60	C40	40
80	C40	40
100	C40	40
125	C40	40
150	C40	40
200	C40	40
250	C40	40
300	C40	40

### Linked products

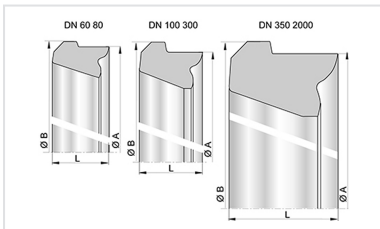

### Standard gasket for Pipes and Fittings DN60-2000

*The information on this sketch is, to the best of our knowledge correct at the time of printing. However Saint-Gobain are constantly looking at ways of improving their products and services therefore reserve the right to change without prior notice, any of the data shown. Any orders placed will be subject to our Standard Conditions of Sale, available on request.*