

## Kit Level Invert Tee with flange branch + Standard Gasket

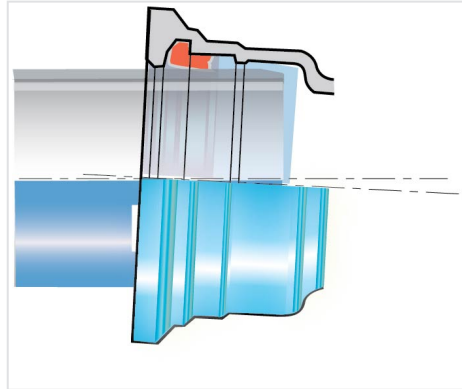

DN	Ø dn	PN	Weight of Kit	References
400	100	10 16	71.16 kg	SSB40UT1FTT-E00
400	100	25 40	72.16 kg	SSB40UT3FTT-E00
500	150	10 16	139.08 kg	SSB50UT1JTT-E00
600	150	10 16	166.32 kg	SSB60UT1JTT-E00
700	200	10	311.64 kg	SSB70UT1KTT-E00
700	200	16	311.84 kg	SSB70UT2KTT-E00
700	200	25	301.92 kg	SSB70UT3KTT-E00
800	200	10	433.34 kg	SSB80UT1KTT-E00
800	200	16	433.34 kg	SSB80UT2KTT-E51
800	200	25	497.34 kg	SSB80UT3KTT-E00
1000	200	10	531.18 kg	SSC10UT1KTT-E00
1000	200	16	531.18 kg	SSC10UT2KTT-E00
1000	200	25	531.18 kg	SSC10UT3KTT-E00

DN mm	Class	PFA bar
60	C40	40
80	C40	40
100	C40	40
125	C40	40
150	C40	40
200	C40	40

DN mm	Class	PFA bar
250	C40	40
300	C40	40
350	C30	30
400	C30	30
450	C30	30
500	C30	30
600	C30	30
700	C25	25
800	C25	25
900	C25	25
1000	C25	25
1100	C25	25
1200	C25	25
1400	C25	25
1500	C25	25
1600	C25	25
1800	C25	25
2000	C25	25

## Linked products

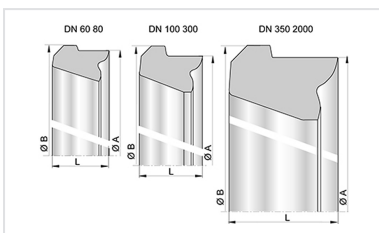

Standard gasket for Pipes  
and Fittings DN60-2000

*The information on this sketch is, to the best of our knowledge correct at the time of printing. However Saint-Gobain are constantly looking at ways of improving their products and services therefore reserve the right to change without prior notice, any of the data shown. Any orders placed will be subject to our Standard Conditions of Sale, available on request.*